

# Self-install Instructions

Cable Standalone (New install) - Self Install Guide

Skyway West - May 2019



## Your finished setup

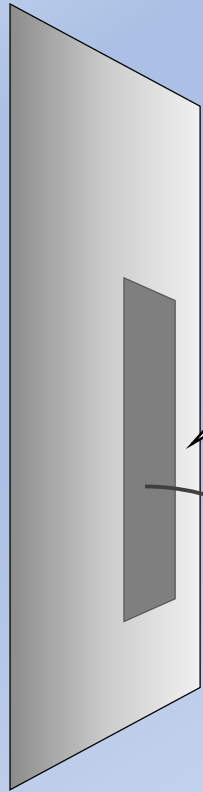

Wall Jack  
Installed by Shaw



Your NEW  
Cable Modem



MikroTik  
Management  
Router



Customer  
Network  
Firewall

# Your Equipment

Thomson TC 4350  
Cable Mode



Back Panel



MikroTik  
Management Router



Panel

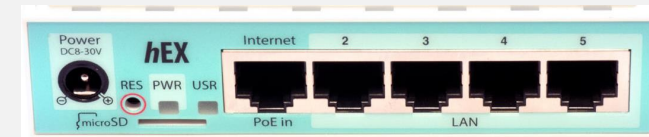

## Connect Cable Modem

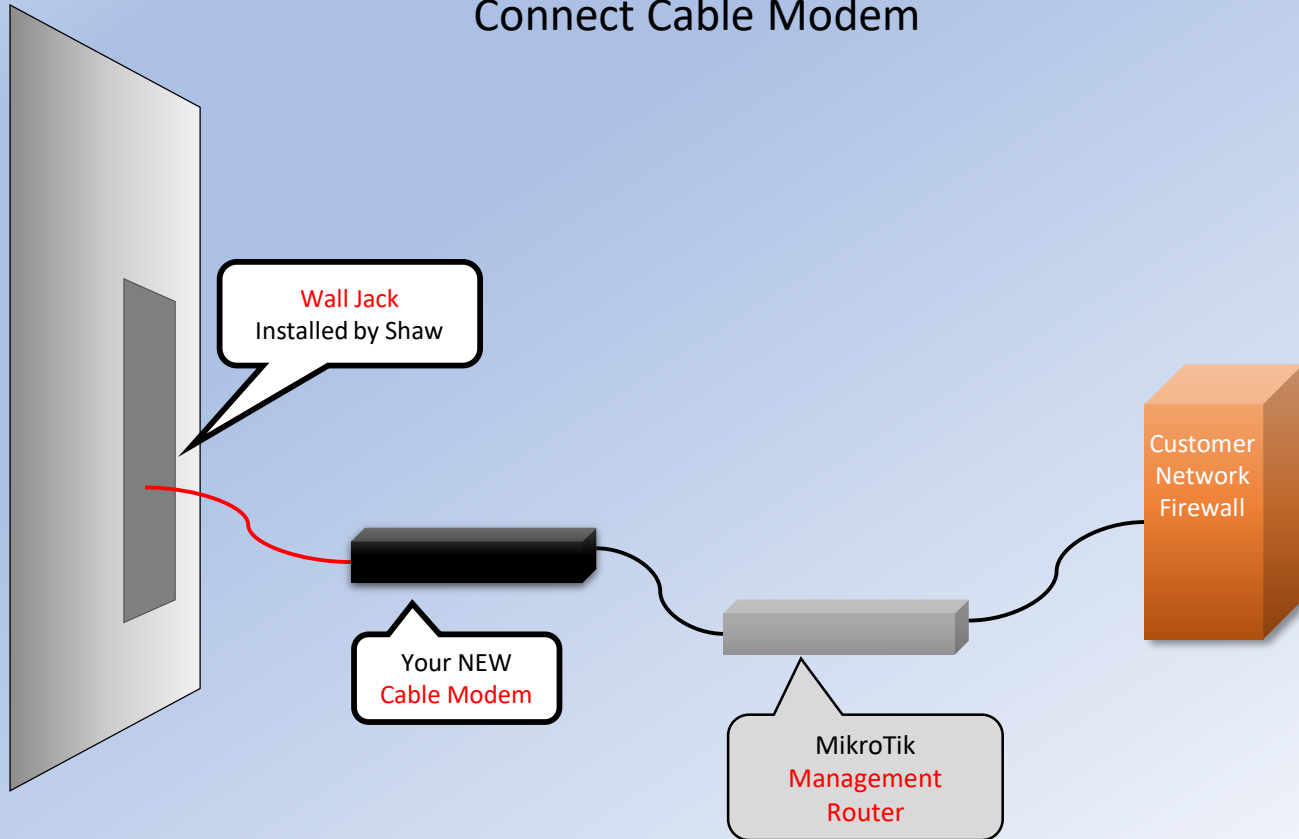

1.

Please connect the coaxial cable from the **wall jack** to the back of your **Cable Modem**



## Connect Management Router

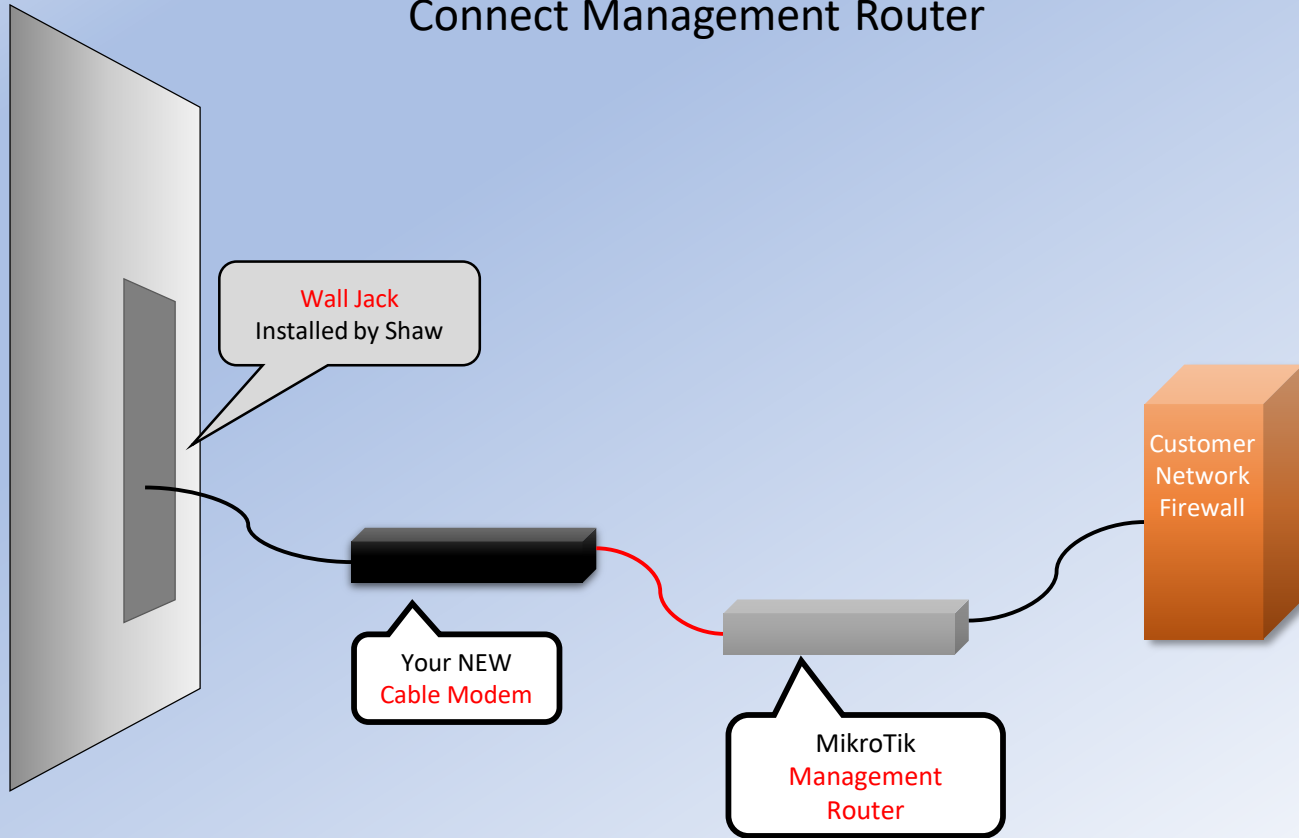

2.

Next, connect the Cat-6 Networking Cable into the **ethernet port** on the back of the **Cable Modem**, and into the **Internet port** (or port 1) on the **Management Router**

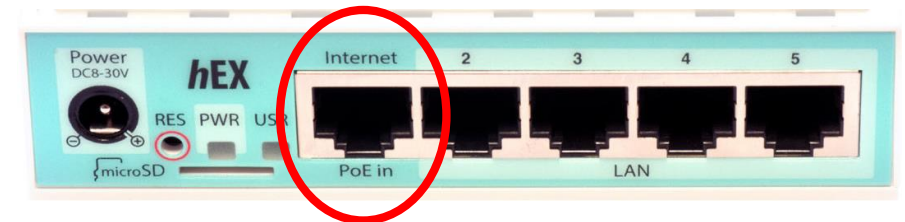

# Standalone Cable Connection Diagram

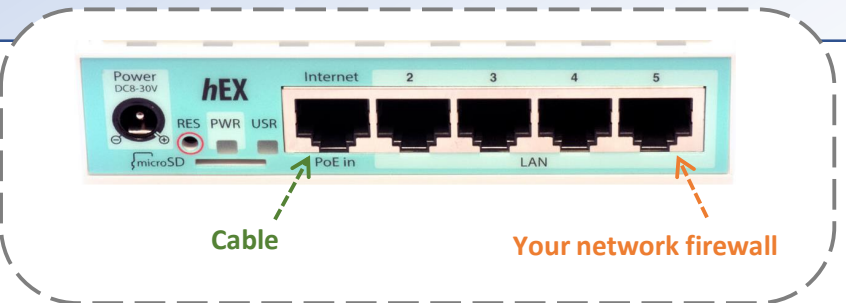
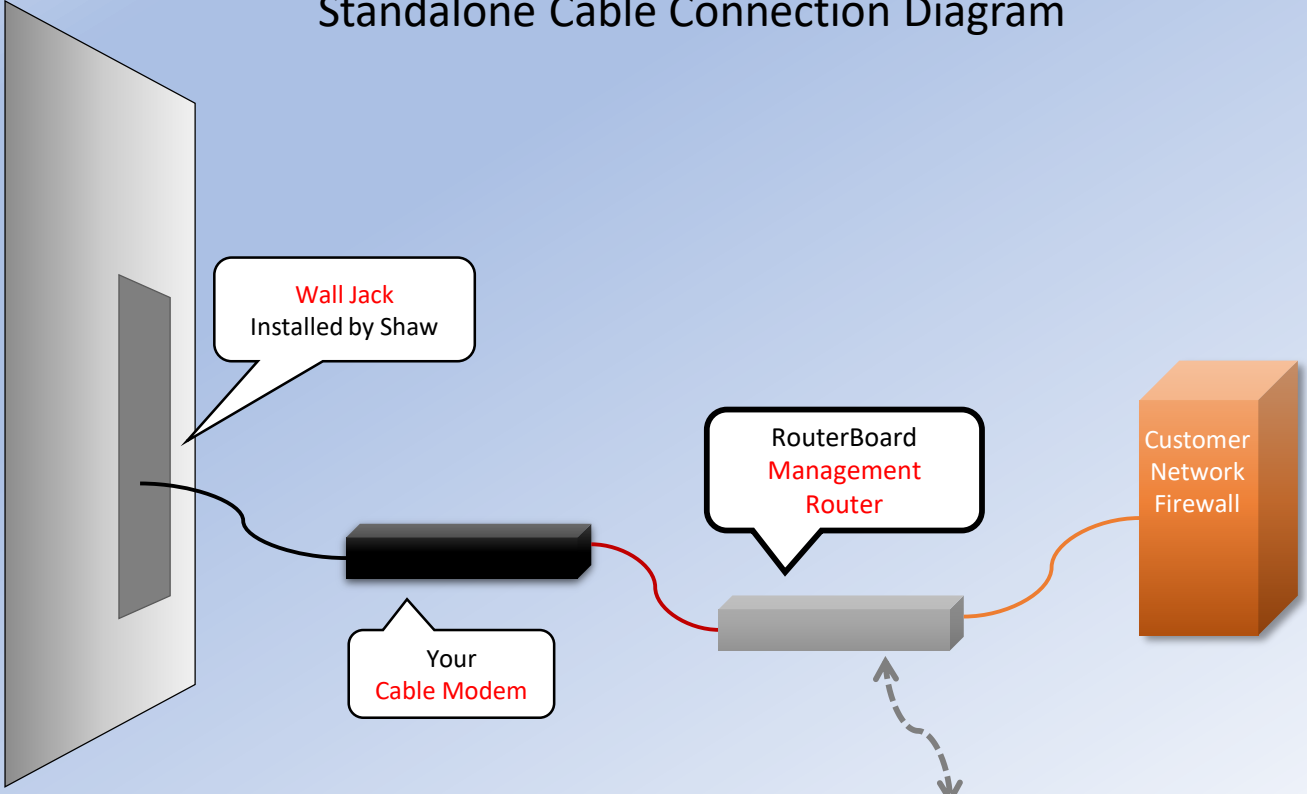

Please call Skyway West Support at **604-482-1212** to verify your configuration and test your service performance .